

**Each boat owner requesting a PHRF rating must complete this application with all data printed and signature affixed. Submit to the DRYA office with a DRYA Membership and Yacht Registration form which can also be found on [www.drya.org](http://www.drya.org).**

SAIL PREFIX \_\_\_\_\_ SAIL NO \_\_\_\_\_ YACHT NAME \_\_\_\_\_

DESIGN \_\_\_\_\_ HULL# \_\_\_\_\_ YEAR \_\_\_\_\_

OWNER \_\_\_\_\_

ADDRESS \_\_\_\_\_

CITY \_\_\_\_\_ STATE \_\_\_\_\_ ZIP \_\_\_\_\_

PHONE (H) \_\_\_\_\_ (W) \_\_\_\_\_

EMAIL \_\_\_\_\_

YACHT CLUB \_\_\_\_\_

ROLLER FURLING: Y N

JIB: ABOVE DECK \_\_\_\_\_ BELOW DECK \_\_\_\_\_  
 MAKE & MODEL # OF ROLLER FURLER \_\_\_\_\_

DIMENSIONS: L-luff \_\_\_\_\_ JLL \_\_\_\_\_  
 JIB ALWAYS FULLY FURLABLE - Y N  
 NUMBER OF HEADSAILS ONBOARD \_\_\_\_\_

MAIN: IN MAST \_\_\_\_\_ IN BOOM \_\_\_\_\_

MODIFICATIONS TO STANDARD BOAT NOT COVERED

\_\_\_\_\_  
 \_\_\_\_\_  
 \_\_\_\_\_ over

DIMENSIONS

HULL: LOA \_\_\_\_\_ LWL \_\_\_\_\_ BEAM \_\_\_\_\_ DRAFT \_\_\_\_\_ DISPL \_\_\_\_\_

Design: LWL \_\_\_\_\_ BEAM \_\_\_\_\_ DRAFT \_\_\_\_\_ DISPL \_\_\_\_\_

RIG: I \_\_\_\_\_ IS \_\_\_\_\_ Des I \_\_\_\_\_ Des IS \_\_\_\_\_

J \_\_\_\_\_ Des J \_\_\_\_\_

P \_\_\_\_\_ Des P \_\_\_\_\_

E \_\_\_\_\_ Des E \_\_\_\_\_

SPL/SPRIT \_\_\_\_\_ SPL/SPRIT \_\_\_\_\_

MAST: Check Material; ALUMINUM \_\_\_\_\_ CARBON \_\_\_\_\_ OTHER \_\_\_\_\_  
 NUMBER OF SPREADER PAIRS \_\_\_\_\_

SAIL MEASUREMENTS

SPINNAKER: SL \_\_\_\_\_ SMW \_\_\_\_\_ SMG \_\_\_\_\_

LARGEST ASSYMETRICAL

ASLU \_\_\_\_\_ ASLE \_\_\_\_\_ ASMW \_\_\_\_\_ ASMG \_\_\_\_\_ ASFT \_\_\_\_\_

LARGEST #1 GENOA LP \_\_\_\_\_ MG \_\_\_\_\_

YEAR SAIL FIRST USED: MAIN \_\_\_\_\_ LT#1 \_\_\_\_\_ HVY #1 \_\_\_\_\_

LT SPIN \_\_\_\_\_ ALL PURPOSE SPIN \_\_\_\_\_ LARGEST ASYM \_\_\_\_\_

VARIABLES: (Check items)

ENGINE: INBOARD \_\_\_\_\_ EXP-SHAFT \_\_\_\_\_ OUTBOARD \_\_\_\_\_ SAILDRIVE \_\_\_\_\_

PROPELLOR TYPE:

FOLDING \_\_\_\_\_ FEATHERING \_\_\_\_\_ IN APERATURE \_\_\_\_\_

FIXED \_\_\_\_\_ SOLID 2-BLADE \_\_\_\_\_ SOLID 3-BLADE \_\_\_\_\_ DIAM \_\_\_\_\_

RUDDER: ATTACHED \_\_\_\_\_ SKEG \_\_\_\_\_ SPADE \_\_\_\_\_ OTHER \_\_\_\_\_

TYPE OF KEEL:

FIN \_\_\_\_\_ FIN+BULB \_\_\_\_\_ TURBO \_\_\_\_\_ FULL \_\_\_\_\_ CB \_\_\_\_\_ SHOAL \_\_\_\_\_

KEEL/BALLAST MATERIAL \_\_\_\_\_

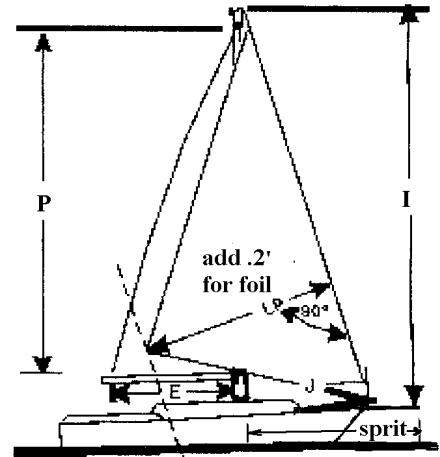

SMW MEAS

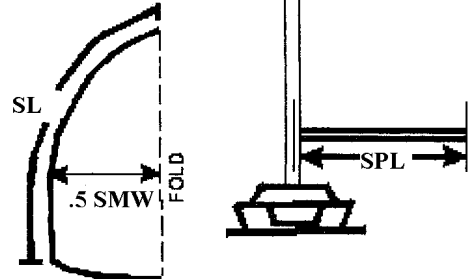

*Changes in roller furling credit must be submitted annually.*  
 Review DRYA Handbook Section 15 on [www.drya.org](http://www.drya.org) for details on measurements and handicapping.

**I UNDERSTAND THAT IT IS THE OWNER'S RESPONSIBILITY TO NOTIFY THE HANDICAP COMMITTEE ABOUT ANY CHANGES IN THE BOAT OR ITS EQUIPMENT.**

Signatures  
 Owner \_\_\_\_\_

\_\_\_\_\_ Date \_\_\_\_\_

Measurer \_\_\_\_\_

\_\_\_\_\_ Date \_\_\_\_\_