

**Each boat owner requesting a PHRF rating must complete this application with all data printed and signature affixed. Submit to the DRYA office with a DRYA Membership and Yacht Registration form which can also be found on [www.drya.org](http://www.drya.org).**

SAIL PREFIX \_\_\_\_\_ SAIL NO \_\_\_\_\_ YACHT NAME \_\_\_\_\_

DESIGN \_\_\_\_\_ HULL# \_\_\_\_\_ YEAR \_\_\_\_\_

ROLLER FURLING: Y N

OWNER \_\_\_\_\_

JIB: ABOVE DECK \_\_\_\_\_ BELOW DECK \_\_\_\_\_  
 MAKE & MODEL # OF ROLLER FURLER \_\_\_\_\_

ADDRESS \_\_\_\_\_

DIMENSIONS: L-luff \_\_\_\_\_ JLL \_\_\_\_\_

CITY \_\_\_\_\_ STATE \_\_\_\_\_ ZIP \_\_\_\_\_

JIB ALWAYS FULLY FURLABLE - Y N  
 NUMBER OF HEADSAILS ONBOARD \_\_\_\_\_

PHONE (H) \_\_\_\_\_ (W) \_\_\_\_\_

MAIN: IN MAST \_\_\_\_\_ IN BOOM \_\_\_\_\_

EMAIL \_\_\_\_\_

**MODIFICATIONS TO STANDARD BOAT NOT COVERED**

YACHT CLUB \_\_\_\_\_

**DIMENSIONS**

HULL: LOA \_\_\_\_\_ LWL \_\_\_\_\_ BEAM \_\_\_\_\_ DRAFT \_\_\_\_\_ DISPL \_\_\_\_\_

\_\_\_\_\_ over

Design: LWL \_\_\_\_\_ BEAM \_\_\_\_\_ DRAFT \_\_\_\_\_ DISPL \_\_\_\_\_

RIG: I \_\_\_\_\_ IS \_\_\_\_\_ Des I \_\_\_\_\_ Des IS \_\_\_\_\_

J \_\_\_\_\_ Des J \_\_\_\_\_

P \_\_\_\_\_ Des P \_\_\_\_\_

E \_\_\_\_\_ Des E \_\_\_\_\_

SPL/SPRIT \_\_\_\_\_ SPL/SPRIT \_\_\_\_\_

MAST: Check Material; ALUMINUM \_\_\_\_\_ CARBON \_\_\_\_\_ OTHER \_\_\_\_\_  
 NUMBER OF SPREADER PAIRS \_\_\_\_\_

**SAIL MEASUREMENTS**

SPINNAKER: SL \_\_\_\_\_ SMW (GIRTH) \_\_\_\_\_

**LARGEST ASSYMETRICAL**

LU \_\_\_\_\_ LE \_\_\_\_\_ SMW \_\_\_\_\_ LP \_\_\_\_\_

LARGEST #1 GENOA LP \_\_\_\_\_

YEAR SAIL FIRST USED: MAIN \_\_\_\_\_ LT#1 \_\_\_\_\_ HVY #1 \_\_\_\_\_

LT SPIN \_\_\_\_\_ ALL PURPOSE SPIN \_\_\_\_\_ LARGEST ASYM \_\_\_\_\_

**VARIABLES: (Check items)**

ENGINE: INBOARD \_\_\_\_\_ EXP-SHAFT \_\_\_\_\_ OUTBOARD \_\_\_\_\_ SAILDRIVE \_\_\_\_\_

**PROPELLOR TYPE:**

FOLDING \_\_\_\_\_ FEATHERING \_\_\_\_\_ IN APERATURE \_\_\_\_\_

FIXED \_\_\_\_\_ SOLID 2-BLADE \_\_\_\_\_ SOLID 3-BLADE \_\_\_\_\_ OTHER \_\_\_\_\_

RUDDER: ATTACHED \_\_\_\_\_ SKEG \_\_\_\_\_ SPADE \_\_\_\_\_ OTHER \_\_\_\_\_

**TYPE OF KEEL:**

FIN \_\_\_\_\_ FIN+BULB \_\_\_\_\_ TURBO \_\_\_\_\_ FULL \_\_\_\_\_ CB \_\_\_\_\_ SHOAL \_\_\_\_\_

KEEL/BALLAST MATERIAL \_\_\_\_\_

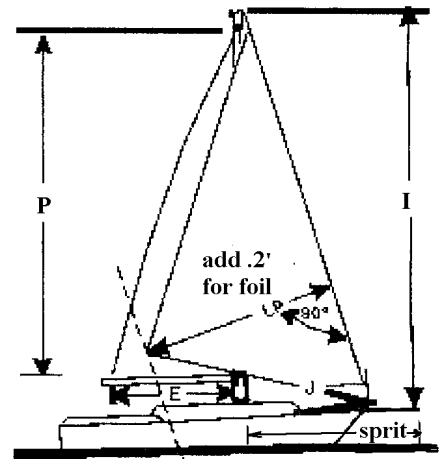

**SMW MEAS**

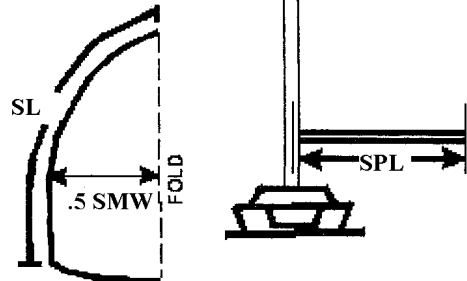

*Changes in roller furling credit must be submitted annually.*  
 Review DRYA Handbook Section 15 on [www.drya.org](http://www.drya.org) for details on measurements and handicapping.

**I UNDERSTAND THAT IT IS THE OWNER'S RESPONSIBILITY TO NOTIFY THE HANDICAP COMMITTEE ABOUT ANY CHANGES IN THE BOAT OR ITS EQUIPMENT.**

Signatures  
 Owner \_\_\_\_\_

Date \_\_\_\_\_

Measurer \_\_\_\_\_

Date \_\_\_\_\_