

2004 INTERNATIONAL MELGES²⁴ CLASS RULES

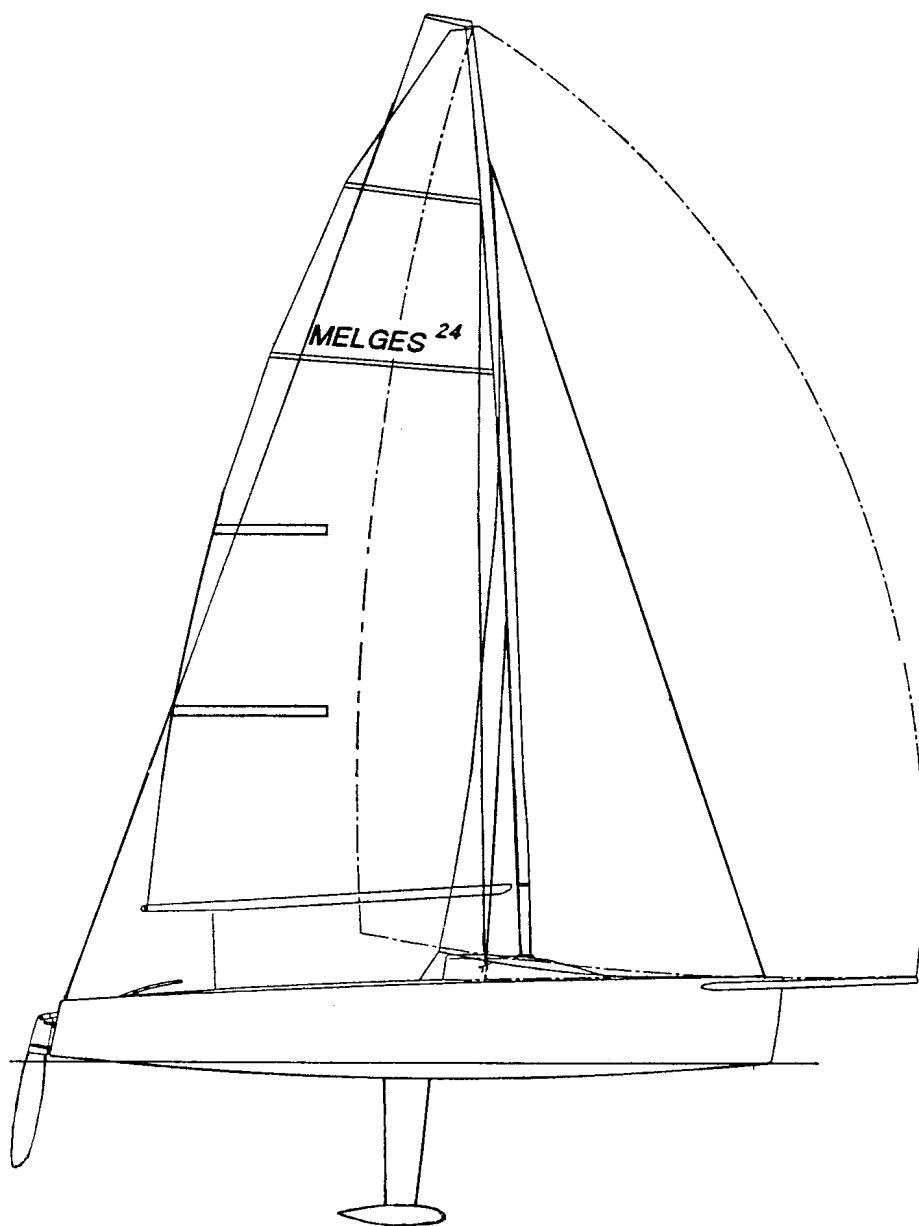

Authority*: International Sailing Federation



* The International Sailing Federation (ISAF) is not a National Authority (NA)

INTERNATIONAL MELGES 24 CLASS RULES 2004

The Melges 24 Class was designed in 1992 by Reichel and Pugh and was adopted as an International class in 1997.

SECTION A - FUNDAMENTAL RULES.

A.1. TYPE OF CLASS RULES.

A1.1. The Melges 24 is a **closed class**.

The intention of these rules is to ensure the boats are as identical as possible in construction, hull shape, weight, weight distribution, equipment, rigging and sail plan. It is impossible to foresee every conceivable innovation which may be thought of in the future and to mention every suggestion that has been ruled illegal in the past. When considering anything in connection with the boat or its sails or equipment which is not within established practice in the Melges 24 Class or involves the use of a material not previously used or accepted by the class or is not clearly covered by the class rules, plans or specification, you must assume that it is illegal, and must obtain a ruling from the Class Technical Committee before attempting it.

A.2. ABBREVIATIONS.

A.2.1.	ISAF.	International Sailing Federation.
	MNA.	ISAF Member National Authority.
	ICA.	International Melges 24 Class Association.
	NCA.	National Class Association.
	ERS.	The Equipment Rules of Sailing.
	RRS.	The Racing Rules of Sailing.

A.3. AUTHORITY.

A.3.1. The international authority of the class is the ISAF which shall co-operate with the ICA in all matters concerning these **class rules**.

A.3.2. Neither the ISAF, an MNA, the ICA, an NCA, the copyright holder or an **official measurer** is under any legal responsibility in respect of these **class rules**.

A.3.3. The Copyright Holder shall be Reichel & Pugh Yacht Design Inc.

A.4. LANGUAGE.

A.4.1. The official language of the class is English and in case of dispute over translation the English text shall prevail.

A.4.2. The word "shall" is mandatory and the words "may" and "can" are permissive.

A.5. ISAF EQUIPMENT AND RACING RULES.

A.5.1. These **class rules** shall be read in conjunction with the ERS and measurements shall be taken in accordance with these unless specified. Where a term is used in its defined sense, it is printed in “**bold**” type if defined in the ERS and in “*italic*” type if defined in the RRS.

A.6. INTERPRETATION.

A.6.1. Any interpretation of the **class rules**, except as provided in A.7, shall be made by the ISAF which shall consult the ICA and the copyright holder. Request for interpretation shall be made by the ICA or an MNA or a licensed builder. (N.B. The right of the class to approve or not, any class rule changes is protected by ISAF regulations and the class constitution.)

A.6.2. In the event of a discrepancy between any rules, drawings, specifications or measurement form the matter shall be referred to the ISAF.

A.7. INTERPRETATION OF THE CLASS RULES AT AN EVENT.

A.7.1. Any interpretation of **class rules** required at an event may be by an international jury constituted in accordance with the RRS, Appendix Q. Such interpretation shall only be valid during the event and the organising authority shall, as soon as practical after the event, inform ISAF, the MNA and the ICA of such interpretation.

SECTION B - ORGANISATION.

B.1 ADMINISTRATION OF THE CLASS.

B.1.1. ISAF has delegated its administrative functions of the class to MNA's. The MNA may delegate part or all of its functions as stated in these **class rules** to a NCA. (N.B. The right of the class to approve or not, any class rule changes is protected by ISAF regulations and the class constitution.)

B.1.2. In countries where there is no MNA, or the MNA does not wish to administrate the class, its functions as stated in these **class rules** shall be carried out by the ICA which may delegate the administration to an NCA.

B.2. INTERNATIONAL CLASS FEE AND ISAF PLAQUE.

B.2.1. The International Class Fee shall be paid by the Licensed Hull Builder to the Copyright Holder.

B.2.2. The Copyright Holder shall, after having received the International Class Fee, send the ISAF Building Plaque, and an official receipt to the Licensed Hull Builder.

B.2.3. The International Class Fee Building Plaque shall be permanently displayed on the starboard side, aft face of the transom.

B.3. SAIL NUMBERS.

B.3.1. Sail numbers shall correspond to the number on the International Class Building Fee Plaque.

B.3.2. In addition, the **boat** shall carry the sail letters applicable to her nationality as per RRS 77 - Appendix H and **class rule** C.1.7 and C.1.8.

B.4. MEASUREMENT CERTIFICATE.

- B.4.1. The owner shall send the completed measurement form to the MNA together with the International Class Fee official receipt and any registration fee that may be required.
- B.4.2. Upon receipt of a correctly completed measurement form the MNA may issue a **measurement certificate**. The MNA shall always retain a copy of the **measurement certificate**.
- B.4.3. A **measurement certificate** is an original or copy of the measurement form, which has been stamped and endorsed by a MNA, or is a **measurement certificate** issued by that MNA.
- B.4.4. Notwithstanding anything contained herein, the MNA may withdraw a **measurement certificate** and shall do so on request of the ISAF. Upon request, an owner is to return the **measurement certificate** to the MNA.
- B.4.5. Fundamental measurement shall be undertaken to the procedures and protocol set on the measurement form. The ICA and an MNA together may appoint one or more persons at the manufacturers to measure and certify the finished boat and sign the measurement form accordingly. The procedure shall be checked by random visits by an official measurer who shall sign the measurement form to this effect. This system shall be accepted as a correctly completed measurement form as per B.4.2

B.5. CHANGE OF OWNERSHIP.

- B.5.1. Change of ownership invalidates the **measurement certificate**, but re-measurement is not required. The new owner shall apply to the MNA for a new **measurement certificate**, returning the old certificate with any re-registration fee that may be required. A new **measurement certificate** shall then be issued to the new owner.

B.6. AMENDMENTS TO CLASS RULES.

- B.6.1. Amendments to these **class rules** shall be proposed by the ICA, or an MNA, and shall be approved by the ISAF. (N.B. The right of the class to approve or not, any class rule changes is protected by ISAF regulations and the class constitution.)

B.7. MEASURERS.

- B.7.1. An **official measurer** shall not measure a **boat** owned, designed or built by himself, or in which he is an interested party, or has a vested interest except where permitted by the **class rules**.
- B.7.2. If an **official measurer** is in any doubt as to the compliance with the **class rules** of any part of a **boat** he shall consult the MNA before signing a measurement form or attaching a **certification mark**.
- B.7.3. An **official measurer** shall only carry out **fundamental measurement** in another country with the prior agreement of the MNA in the country where measurement shall take place.
- B.7.4. A measurer shall seek approval from the ICA, but shall only be an **official measurer** when recognised or appointed by a MNA.

B.8. AXES AND POINTS OF MEASUREMENT.

- B.8.1. Except where other methods of measurement are specifically indicated all measurement shall be carried out in accordance with the ERS and the ISAF Guide to Measurers.

- B.8.2. Words such as “fore”, “aft”, “above”, “below”, “height”, “depth”, “length”, “beam” and “freeboard” acquire a precise meaning in measurement as they are all taken to refer to a boat in measurement trim. All measurement denoted by these or similar words, shall be taken parallel to one of the three major axes of the hull - vertical, horizontal or transverse - related to the waterline and the centerplane of the **hull**.
- B.8.3. Where a measurement is to be taken between two points, the distance between these points shall be taken whether or not parallel to an axis.
- B.8.4. Width, thickness, length etc of a component shall be measured as appropriate for that component, without reference to the **hull** axes.
- B.8.5. The fore and aft position of deck fittings shall be measured from the forward side of a straight measurement beam (MB) minimum 2400mm in length, (not less than 100mm wide), laid across the boat on the deck and against the aft face of the cabin. Measurements shall be taken parallel to the fore and aft centreline of the yacht. The beam may have cut outs to fit around any instruments fitted in the aft face of the cabin.
- B.8.6. The Hull Datum Point (HDP) is the intersection, on the centerplane of the **hull** between the underside of the shell and the transom upstand, each extended as necessary.

B.9. MEASUREMENT EQUIPMENT.

- B.9.1. Measurement equipment shall be accurate to at least half the value of the last significant figure specified in the **class rules**.
- B.9.2. Templates shall be the official templates made from the ISAF design and registered with the ISAF. Tolerances shall be inscribed on the templates.

B.10. CHECKING MATERIALS.

- B.10.1. An **official measurer** is not required to check materials unless the **class rules** specifically prescribe this.

SECTION C - CONDITIONS FOR RACING.

The crew and the **boat** shall comply with the rules in this section before the preparatory signal and, when applicable, whilst *racing*. These rules may not be checked as part of **fundamental measurement**. It is the Owners responsibility to see that his **boat** complies with the **class rules** and relevant RRS at all times and that alteration, replacement or repairs to the **boat** do not invalidate the **measurement certificate**.

Items referred to in these **class rules** shall only be used for the purpose stated.

C.1. CERTIFICATE AND IDENTIFICATION MARKS.

- C.1.1. No **boat** shall take part in class races unless it has a valid **measurement certificate**.
- C.1.2. New or substantially altered sails shall be measured by an official measurer who shall stamp with the officially issued class stamp and sign and date the sails in vicinity of the tack

C.2. EQUIPMENT.

C.2.1. **Mandatory:**

1. Engine: minimum nominal power of 2 kilowatts (3hp).
Minimum weight 12.5 kgs. (empty of fuel).

When not in use engine and outboard bracket shall be stowed in the engine berth below the main cockpit.

2. The boat shall depart the dockside with the engine tank full and a separate container with a minimum of 3ltrs of fuel. Container complying with boats MNA or local regulations.
3. One anchor and chain: minimum anchor weight 3.1kgs.
minimum combined weight 5kgs.
One warp: minimum length 40 metres.
minimum diameter 8mm.
4. One manual bilge pump.
5. One bucket of not less than 9 ltrs capacity, with lanyard minimum 1 metre.
6. Personal flotation vests shall be carried for each crew member on board.
7. **Boats** shall comply with any special requirements of the MNA under which racing is being held or those set by the club or local marine authority. Boats shall comply with any special requirements of the MNA under which racing is being held or those set by the club.
8. The two main companionway hatches to enable the cabin to be closed off.
9. The engine tray shall be carried under the engine.

C.2.2 **Optional.**

1. Electronic timing devices.
2. Navigation lights, tactical and navigation instruments and their associated power sources.
3. A cool/ice box may be carried.
4. Bunk cushions and a portable toilet may be carried. The cushions shall be on the bunks and the toilet shall be stowed under the companionway step.
5. The mast may be fitted with a gaiter below the gooseneck to prevent damage from the jib clew and blocks.
6. The companionway hatches may be stowed in a protective bag.
7. The spinnaker may be stowed in a bag in the companionway hatch. The design of this bag is optional.
8. The moulded gel coat below the waterline and for not more than 30mm above the waterline may be lightly abraded back to allow for the application and adhesion of anti-fouling products, for those boats to be left afloat. The abrasion of the gel coat shall be the minimum needed to ensure adhesion of the coating and shall not involve fairing of any sort. The application of paint and epoxy treatments, whilst allowed, shall be subject to rule D.7.2. and be completed under the supervision of a measurer.

9. The 6 hatches from the cabin 'V' berth/settees.

C.2.3. Limitations

- C.2.3.1. Not more than 1 mainsail, 1 headsail and 2 spinnakers shall be carried on board. The headsail and mainsail shall not be changed or substituted whilst underway or away from the dockside. The mainsail shall at all times be set within the limits set by the **mast** and **boom bands**.
- C.2.3.2. Not more than 1 mainsail 1 headsail and 2 spinnakers shall be presented for measurement and/or registration at a class event.
- C.2.3.3. The keel shall be retractable using the Melges designed lifting crane. The keel shall be secured in the down position whilst racing using the supplied locking strap.

C.3 FITTINGS.

- C.3.1. There shall be only one jib sheet track to port and one to starboard. They shall be positioned as per rule D.6.1.4. The position shall not be modified. Additional location holes may be drilled in the track to position the jib car.
- C.3.2. The sheet cars and their associated blocks for the sheeting of the jib, shall be on the jib sheet tracks and no other method of sheeting the jib shall be permitted.
- C.3.3. The manufacturer or brand of the blocks and winches is optional. The sheave height from fixing point and sheave diameter shall not exceed the following dimensions.

		Minimum	Maximum.
Jib clew blocks.	Sheave dia.	26mm.	30mm.
Jib car blocks.	Sheave dia.	42mm.	46mm.
Jib car blocks:			
Top surface of jib car to bearing surface of	Sheave	50mm.	54mm.
Jib ratchet blocks.	Sheave dia.	74mm.	78mm.
Mainsheet track block.	Sheave dia.	54mm.	58mm.
Mainsheet boom blocks.	Sheave dia.	54mm.	58mm.
Mainsheet ratchet block.	Sheave dia.	54mm.	78mm.
Spinnaker turning blocks.	Sheave dia.	54mm.	78mm.
Spinnaker deck ratchet blocks.	Sheave dia.	74mm.	78mm.
Bowsprit end block.	Sheave dia.	Optional	
All control line blocks.	Sheave dia.	Optional	
Hiking line blocks	Sheave dia.	Optional.	

The spinnaker tack line cleat may be changed to a stopper.

- C.3.4. The position of the winches or ratchet blocks for the spinnaker and jib and their associated cleats is optional. There shall be not more than two cleats per side for the jib.
- C.3.5. The spinnaker turning blocks may be either free running or ratchet blocks of size as per **class rule C.3.3**.
- C.3.6. The traveller and backstay cleats may be placed within a box measuring 1900mm and 2150mm aft of the MB and between the lower edge of the deck non skid and a line 180mm below this edge on the cockpit moulding.
- C.3.7. A block may be added above the traveller cleat to assist in tacking the traveller in light winds.

- C.3.8. The mainsheet track shall be fitted at minimum 2260mm, maximum 2370mm aft of the MB. The mainsheet swivel cleat may be fitted either forward or aft the mainsheet track. Alternatively the mainsheet swivel cleat may be removed and the cleat mounted on the lower block. The upper two single blocks may be combined into a double block.
- C.3.9. The rear gate line across the transom shall be closed whilst racing.
- C.3.10. The hiking line shall be attached at the deck fitting forward and to the designed eye on the pulpit aft. The method of attachment is optional.
- C.3.11. spare
- C.3.12. Padding may be fitted to the hiking lines to enhance crew comfort. The line may be either a continuous line with padding or two lines linked by a webbing section between the two stanchions used for hiking. The method of joining the hiking line and the webbing is optional. The webbing shall be a minimum of 50mm wide.
- C.3.13. When pushing down hard on the hiking lines at the mid point between the two centre stanchions, no part of the hiking line including padding etc shall touch the deck.
- C.3.14. From the aft stanchion, the hiking line may be led down and through either a block or a shackle attached to the spinnaker turning block deck eye, or through the deck eye itself, and up to the stern pulpit.
- C.3.15. Bags for the storage of rope tails and miscellaneous equipment may be attached to the cockpit moulding.
- C.3.16. Additional foot chocks may be fitted to the cockpit floor, including moulded foot chocks and engine hatch cover. The shape is optional. They shall not exceed 50mm in height above the surface to which they are fitted.
- C.3.17. A proprietary hatch not exceeding 220mm in internal diameter may be fitted to the cockpit floor to allow access to the rudder and backstay fittings.
- C.3.18. A watertight drain bung may be fitted to the transom.
- C.3.19. Protective covers to prevent water ingress and abrasion may cover the shrouds, vang and recess for the furler drum.

C.4. RIGGING.

- C.4.1. Additions to or subtractions of purchase, to the mainsheet system, spinnaker sheet system, main cunningham, boom vang, main outhaul, jib sheet system, traveller controls, bowsprit launch systems, backstay or reefing systems shall not be permitted. The cunningham may be led through the mainsail eye/block and tied off on the gooseneck fitting.
- C.4.2. The complete boom vang unit as supplied may be fitted with the cleat at either mast or boom end.
- C.4.3. No lines shall lead below deck other than the main halyard, jib halyard, jib furling line and the bow sprit launch and recovery line with tackle.
- C.4.4. Control lines and sheets may be tapered. Diameter of mainsheet, jib sheets, spinnaker sheets and control lines are optional.
- C.4.5. A single gybe line may be spliced into the spinnaker sheets at the clew to ease gybes. The sheets shall not be spliced onto the clew.
- C.4.6. The shrouds may be attached and adjusted by turnbuckles/bottle screws of optional design except that only one thread is permitted per turnbuckle. Lock plates may be fitted to maintain the rig

setting. They may be adjusted whilst racing, but at the chainplate only. Remote adjustment of any type is prohibited.

C.4.7. Except as in C.6.3.4, the use of shock-cord is un-restricted.

C.5. HULL WEIGHT.

C.5.1. The weight of the complete **boat**, dry and in racing condition at building specification shall be not less than 809kgs. Excluded from this weight shall be only: Sails - Engine, Bracket and Fuel Can - Anchor, Chain and Warp - Manual Bilge Pump - Bucket and Lanyard - Floatation Vests - All equipment listed in **class rule** C.2.2. except that the fittings in C.2.2.1. and C.2.2.2. that are permanently fixed to the boat (e.g. display heads and sensors) may be included in the weight. N.B. Batteries or power sources of any sort shall be removed before weighing.

C.5.2. Corrector weight:

Shall not exceed 20 kg

Shall be of lead

Shall be equally divided fore and aft and fixed in the locations shown on the measurement diagram. The aft corrector weight on the fore side of the bulkhead may be split equally port and starboard.

Shall be entered on the **certificate**

May only be altered after the **boat** has been re-weighed by an **official measurer**.

Shall not be reduced more than once every 12 months

C.6. SPARS.

C.6.1. Mast.

C.6.1.1. Mast weight:

Complete with all standing and running rigging.

Tip weight:

Minimum.

Maximum.

28kgs.

10kgs.

C.6.1.2. The mast head crane shall be fitted with a sail batten, connected to the backstay. The sail batten shall be used to assist keeping the backstay clear of the mainsail leech. The length and specification of this sail batten is optional, and it may be fitted with a ring, block or similar.

C.6.2. Main Boom.

C.6.2.1. Spar band width:

Boom band distance:

Minimum.

Maximum.

15mm.

3800mm.

C.6.2.2. The boom shall be fitted with a clew outhaul system.

C.6.2.3. The cleat and line for the mainsail reef is optional.

C.6.2.4. A shackle, block or similar device, may be fitted to the underside of the boom to help guide the spinnaker halyard during retrieval of the spinnaker.

C.6.3. Bow Sprit.

- C.6.3.1. The bowsprit shall be capable of being retracted to have its forward end level with or aft of the forward side of the stem. The bowsprit shall be retracted when the spinnaker is not flying. To help ensure a watertight seal, tape or other material may be added around the bowsprit.
- C.6.3.2. The bowsprit shall extend not more than 1400mm forward of the foreside of the stem. This shall be measured in a straight line from the forward side of the stem to the centre of the bowsprit 'U' bolt in the same plane as the bowsprit.
- C.6.3.3. The bowsprit retraction line is optional. If not fitted, the bowsprit may be retracted by a knot in the spinnaker tack line. However, the requirements of **class rule** C.6.3.1. still apply.
- C.6.3.4. The bow sprit shall not be retracted by shockcord or similar.
- C.6.3.5. To assist in catching the spinnaker sheets, the bow sprit may be fitted with a batten or similar device at the outer end. This shall not extend more than 150mm from the outer end of the bowsprit.

C.7. CREW.

- C.7.1. The minimum number of crew is 3.
- C.7.2. The total crew weight on board while racing shall not exceed 360kgs. This weight shall be taken with the crew dressed in normal underclothes only. Crews shall only be weighed during the registration period prior to racing. Re-weighing shall only take place if a valid protest shows that the pre-race weights were false.
- C.7.3. Competitors shall not wear or carry clothing or equipment for the purpose of increasing their weight.
- C.7.4. **RRS 43.2** shall apply. See also **class rule** D.6.1.10.

C.8. ADVERTISING.

- C.8.1. Advertising for the Melges 24 Class shall at all times comply with RRS 79 and the ISAF Advertising Code, Category C, except as modified in C.8.2. All Melges 24 Class racing shall take place under this category.
- C.8.2. The following restrictions on advertising shall apply. The number of advertisers is unrestricted.

HULL: (i) The area 2.4m long, aft of any Bow numbers shall be kept free for event advertising.
(ii) The remaining area may carry advertising chosen by the boat to a total maximum length of 3m.
(iii) The cockpit may carry advertising chosen by the boat to a maximum length of 1.5m
(iv) The deck may carry advertising chosen by the boat of not more than one advertiser and of unrestricted area. The advert may connect to the advert on the hull side.

HULL APPENDAGES: Advertising chosen by the boat may be displayed on the keel fin and bulb, rudder and tiller. The area is unrestricted and each item may display a different advertiser.

MAST: Advertising chosen by the boat may be displayed on the mast. The maximum length of the adverts shall be 3.2m. Different advertisers may be on each side of the mast.

BOOM: Advertising chosen by the boat may be displayed on the boom. The maximum length of the adverts shall be 2.6m. Different advertisers may be on each side of the boom.

SAILS:

SPINNAKER: Unrestricted.

JIB: No advertising allowed.

MAINSAIL: At all times the advertising shall be below and clearly separated from the national letters and sail numbers. Not more than one advertiser chosen by the boat may be displayed on each side of the Mainsail. The advert shall have a maximum length of 2.6m and a maximum height of 1.3m.

C.9. MEMBERSHIP.

- C.9.1. The owner and helmsman shall be a current member of the NCA or, where there is no NCA in his country, a member of the ICA or an NCA nominated by the ICA.

C.10 BOAT HANDLING RULES.

- C.10.1. Approaching a windward mark without the spinnaker set, the bowsprit shall not be extended until the bow of the boat has passed the mark. If for a windshift, or any other reason, the spinnaker is flown on a 'windward ' leg, then the bowsprit shall be fully extended and the spinnaker set before the boat reaches the two hull length circle at a mark.
- C.10.2. The boat shall fly the spinnaker at all times when the bowsprit is extended.
- C.10.3. The bow sprit shall be retracted at the first reasonable opportunity after rounding the leeward mark.
- C.10.4. The skipper or crew shall not hike out by sitting facing outboard over the spinnaker turning block. The skipper/helmsman shall not sit in any way that projects the body below the waist beyond the sheerline, nor shall they use any fitting or device with which to hike from any part of the body below the waist.
- C.10.5. When roll tacking standing up and hanging on the shrouds shall be prohibited.
- C.10.6. RRS 42.3(b) is modified to allow the spinnaker sheet to be trimmed without restriction in all conditions.

SECTION D - HULL.

D.1. MEASUREMENT AND CERTIFICATION.

- D.1.1. The **hull** shall conform with the **class rules** in force at the time of **fundamental measurement**.
- D.1.2. Measurement shall be carried out in accordance with the **ERS**
- D.1.3. If a **hull** has been substantially altered or repaired its **measurement certificate** shall cease to be valid until the relevant parts of the **hull** have been re-measured and the **measurement certificate** re-validated by the MNA.

D.2. BUILDERS.

- D.2.1. **Hull** builders shall be licensed by the Copyright Holder.
- D.2.2. The licensed builder shall, at his own expense, correct or replace any **hull** that does not comply with the **class rules** as a result of an omission or error by the builder, if the **hull** is submitted for **fundamental measurement** within twelve months of purchase.
- D.2.3. The ISAF building plaque shall be fixed by the builder on the starboard side, aft face of the transom.

D.2.4. All **boats** shall carry an official serial number moulded into or securely fixed to the starboard side, aft face of the transom. This number shall be issued as part of a National requirement such as European Standard EN ISO 10087 : 1996 for those relevant countries. Where the builder does not have to conform to a National requirement, the number shall be from a series formulated by Melges Boatworks Inc. No yacht shall be deemed legal without this number.

D.2.5. Builders shall only build boats and components from moulds taken from master tooling and approved by the Copyright Holder and ISAF, or an organisation approved by the ISAF.

D.3. HULL SHELL.

D.3.1. Materials.

D.3.1.1. The **hull** shall be constructed of glass reinforced materials specified within the builders license.

D.3.1.2. Coring, drilling out, rebuilding, replacement of material, grinding or relocating standard equipment, fairing exterior parts or hull that improves moments of inertia, or changes the standard shapes shall be prohibited. Except that through hull and through core knotmeters and depth sounders shall be allowed. The measurer, the ICA, the MNA or the ISAF may use destructive testing methods to determine compliance with this rule."

D.3.1.3. The sanding of the **hull** to reshape hull profiles or contours shall be prohibited.

D.3.1.4. The fairing of the keel box area, or the keel box "delrins" shall be prohibited, excepted that they may be adjusted to fit flush with the **hull** underside.

D.3.1.5. Through **hull** devices for bailing or self bailing shall be prohibited. One drain plug not exceeding 25mm internal diameter may be fitted in the transom for draining internal water when ashore.

D.3.2. Dimensions.

D.3.2.1. The **hull** shall be constructed from official moulds and conform to the official templates.

D.4. DECK.

D.4.1. Materials.

D.4.1.1. The **deck** shall be constructed of glass reinforced materials specified within the builders license.

D.4.1.2. Coring, drilling out, rebuilding, replacement of material, grinding or relocating standard equipment that improves moments of inertia, or changes the standard shapes shall be prohibited. The measurer, the ICA, the MNA or the ISAF may use destructive testing methods to determine compliance with this rule.

D.4.1.3. The sanding of the **deck** to reshape profiles or contours shall be prohibited.

D.4.2. Dimensions.

D.4.2.1. The **deck** shall be constructed from official moulds.

D.5. INTERNAL STRUCTURE.

D.5.1. Materials.

- D.5.1.1. The interior, bulkheads hatches and other mouldings shall be constructed of glass reinforced materials specified within the builders license.
- D.5.1.2. Coring, drilling out, rebuilding, replacement of material, grinding or relocating standard equipment on any of the above mouldings that improves moments of inertia, or changes the standard shapes shall be prohibited.
- D.5.1.3. The sanding of any of the above mouldings to reshape profiles or contours shall be prohibited.

D.6. COMPLETE HULL.

D.6.1. Fittings.

- D.6.1.1. Fittings shall be fixed in accordance with the specifications of the builders license and shall not be modified unless stated herein.
- D.6.1.2. The fore and aft position of deck fittings shall be measured from the measurement beam (MB), as per rule B.8.5.
- D.6.1.3. The chainplates shall be placed in accordance with the builders specification and shall not be modified or moved. The upper and lower shrouds shall intersect the deck at minimum 360mm, maximum 390mm forward of the MB. The athwartships centre of the chainplate fitting shall be minimum 1725mm, maximum 1750mm apart, equally spanning the boat fore and aft centreline. Both measurements shall be taken on the leading face of the chainplate at hole centreline.
- D.6.1.4. The jib tracks shall be minimum 478mm, maximum 486mm in length. They shall be positioned such that the leading edge of the track is minimum 510mm, maximum 530mm forward of MB. The centreline of the tracks shall lie alongside the cabin sides on the level deck on the inboard edge of the non-slip moulding. Measured by jig across the centreline of the boat the total distance between the centreline of the track forward shall be minimum 978mm, maximum 1000mm, and the centreline of the track aft shall be minimum 1012mm, maximum 1032mm.
- D.6.1.5. The positions of the aft spinnaker turning block deck plates shall have their centres at minimum 2650mm, maximum 2670mm aft of the MB. They shall be minimum 15mm, maximum 25mm from outboard edge of the deck moulding.
- D.6.1.6. The forward edge of the mast step shall be minimum 2405mm, maximum 2415mm from the aft face of the jib furler drum recess at deck level measured in a straight line.
- D.6.1.7. Two stanchions, a stern pulpit and one hiking line shall be fitted to each side of the boat. The stanchions and pulpits shall be of stainless steel construction as specified in the building specification.
- D.6.1.8. The forward end of the hiking line shall be fixed to the deck at minimum 2470mm, maximum 2500mm forward of the MB. They shall be attached to builders specified deck fittings, or fittings of equivalent strength.
- D.6.1.9. A bow pulpit is optional. If fitted, it shall be as per the building specification.
- D.6.1.10. There shall be one hiking line only per side. The underside of the hole in the stanchion shall be: minimum 450mm, maximum 475mm above the deck. The line shall be either 7 x 19 coated stainless steel wire minimum 3.1mm or HMPE line of minimum 4.5mm, eg. Spectra®.

D.6.1.11. For the purpose of **RRS 43.2** the hiking lines shall be regarded as per **RRS 49.2**, except that the tension may be modified as in **class rule C.3.13**.

D.7. ADDITIONAL RULES.

D.7.1. Sanding is prohibited on all hull, deck and internal structures unless repair of superficial damage is required. If there is any doubt to the interpretation of “superficial damage”, a ruling shall be sought from a measurer or the technical committee before repair work commences and the **boat** offered for re-measurement on completion.

D.7.2. If the **hull** requires to be painted to repair a damaged gelcoat, the process shall be reported to a measurer and the boat offered for re-measurement on completion.

D.7.3. Normal proprietary polishes may be used on the hull if in compliance with **RRS 53**.

D.7.4. The moulded gel coat below the waterline and for not more than 30mm above the waterline may be lightly abraded back to allow for the application and adhesion of anti-fouling products, for those boats to be left afloat. The abrasion of the gel coat shall be the minimum needed to ensure adhesion of the coating and shall not involve fairing of any sort. The application of paint and epoxy treatments, whilst allowed, shall be subject to rule D.7.2. and be completed under the supervision of a measurer.

SECTION E - HULL APPENDAGES.

E.1. MEASUREMENT AND CERTIFICATION.

E.1.1. Hull appendages shall conform with the **class rules** in force at the time of **fundamental measurement**.

E.1.2. Measurement shall be carried out in accordance with the **ERS**.

E.1.3. A MNA may appoint one or more persons at a manufacturer to measure and **certify** hull appendages produced by that manufacturer. A special license shall be awarded for that purpose.

E.1.4. The **official measurer** shall attach the official **certification sticker**, showing the date of **fundamental measurement**, to approved rudder blades, tillers and keel fins.

E.1.5. Substantially altered or repaired hull appendages shall be re-measured and the **official measurer** shall attach a new official **certification sticker** showing the new date of **fundamental measurement**.

E.2. MANUFACTURERS.

E.2.1. Manufacturers shall be licensed by the Copyright Holder.

E.2.2. The manufacturer shall, at his own expense, correct or replace any **hull appendage** that does not comply with the **class rules** as a result of an omission or error by the manufacturer, if the **hull appendage** is submitted for **fundamental measurement** within twelve months of purchase.

E.2.3. Each hull appendage shall have a unique serial number – on the side of the rudder head and on the part of the keel fin that remains inside the boat – the latter which shall be recorded on the measurement form. The keel fin and keel bulb shall at no time be transferred from one hull to another without full re-measurement to the current rules and templates.

E.2.4. Manufacturers shall only build hull appendages from moulds approved by the Copyright Holder and ISAF, or an organisation approved by the ISAF.

E.2.5. Hull appendages shall conform to the official templates.

E.3. KEEL FIN AND KEEL BULB.

E.3.1. Materials

E.3.1.1. The hull appendages shall be constructed of carbon fibre reinforced materials and lead specified within the manufacturers license.

E.3.1.2. Coring, drilling out, rebuilding, replacement of material, grinding or relocating standard equipment that improves moments of inertia, or changes the standard shapes shall be prohibited.

E.3.1.3. The sanding of the keel fin or keel bulb to reshape profiles or contours shall be prohibited.

E.3.2. Fittings.

E.3.2.1. The forward edge of the keel shall be fitted with a kelp cutter to the Melges design. The slot in which the cutter operates shall not be filled or covered.

E.3.2.2. The keel fin shall be fitted with a removable stainless steel ring used to lift the keel with the Melges crane.

E.3.3. Dimensions.

E.3.3.1 The measurement around the hull on the yachts centreline from the **HDP** to the intersection of the hull and fin trailing edge shall be: minimum 3482mm, maximum 3494mm.

E.3.3.2 With the keel fully lowered, the straight line measurement from the **HDP** to the intersection of the fin trailing edge and the top of the keel bulb shall be: minimum 3784mm, maximum 3823mm.

E.3.3.3 With the keel fully lowered, the measurement from the underside of the hull to the top of the keelbulb, measured in a straight line between the hull/ fin intersection and fin/ bulb intersection, at the trailing edge of the keel shall be : minimum 1195mm, maximum 1215mm.

E.3.3.4 The keel fin and keel bulb shall not be reshaped, faired, or sanded except to facilitate the repair of superficial damage. If there is any doubt to the interpretation of "superficial damage" a ruling shall be sought from an official measurer or the technical committee before work commences and the item offered for re-measurement on completion.

E.3.4. Weight.

	Minimum.	Maximum.
E.3.4.1. Combined keel fin and keel bulb:	300kgs	313kgs.

E.4. RUDDER AND TILLER.

E.4.1. Materials

E.4.1.1. The rudder and tiller shall be constructed of carbon fibre reinforced materials specified within the manufacturers license.

E.4.1.2. Coring, drilling out, rebuilding, replacement of material, grinding or relocating standard equipment that improves moments of inertia or changes the standard shapes shall be prohibited.

E.4.1.3. The sanding of the rudder or tiller to reshape profiles or contours shall be prohibited.

E.4.2. Fittings.

E.4.2.1. A tiller extension shall be optional. If fitted its overall length measured perpendicular to the tiller surface shall be not more than 1100mm.

E.4.2.2. The rudder shall be attached to the transom by means of 2 custom made Melges pintles on the rudder and 2 custom made Melges fittings, with loose pin or pins, on the transom. These fittings shall comply with official drawings.

E.4.3. Dimensions.

E.4.3.1. The rudder head between gudgeons shall be parallel to the transom, +/- 2mm.

E.4.3.2. The measurement from the **HDP** to the trailing edge rudder tip shall be not more than 1220mm.

E.4.3.3. The rudder shall not be reshaped, faired, or sanded except to facilitate the repair of superficial damage. If there is any doubt to the interpretation of "superficial damage" a ruling shall be sought from an official measurer or the technical committee before work commences and the item offered for re-measurement on completion.

E.4.4. Weights.

	Minimum.	Maximum.
E.4.4.1. Rudder including gudgeons and mounting bolts:	7.5 kgs.	
Tiller including extension and bolt to fix tiller to rudder:	1.8 kgs.	

E.5. ADDITIONAL RULES.

E.5.1. Normal proprietary polishes may be used on the hull appendages in compliance with **RRS 53**.

E.5.2. Shims may be fitted between the rudder and tiller to ensure a good fit.

SECTION F - RIG.

F.1. MEASUREMENT AND CERTIFICATION.

F.1.1. The **rig** shall conform with the **class rules** in force at the time of **fundamental measurement**.

F.1.2. Measurement shall be carried out in accordance with the **ERS**.

F.1.3. A MNA may appoint one or more persons at a manufacturer to measure and **certify masts, booms** and **bowsprits** produced by that manufacturer. A special license shall be awarded for that purpose.

F.1.4. The measurer shall attach an official **certification mark** showing the date of **fundamental measurement** to approved **spars**.

F.1.5. Substantially altered or repaired **spars** shall be re-measured and the **official measurer** shall attach a new official **certification mark** showing the new date of **fundamental measurement**.

F.2. MAST.

F.2.1. Manufacturer.

- F.2.1.1. Manufacturers shall be licensed by the Copyright Holder.
- F.2.1.2. The manufacturer shall, at his own expense, correct or replace any **spar** that does not comply with the **class rules** as a result of an omission or error by the builder, if the **spar** is submitted for **fundamental measurement** within twelve months of purchase.
- F.2.1.3. spare
- F.2.1.4. Manufacturers shall only build **spars** from moulds approved by the Copyright holder and ISAF, or an organisation approved by the ISAF.

F.2.2. Materials

- F.2.2.1. The **mast** shall be constructed of carbon fibre reinforced materials specified within the manufacturers license.
- F.2.2.2. Coring, drilling out, rebuilding, replacement of material, grinding or relocating standard equipment that improves moments of inertia, or changes the standard shapes shall be prohibited.
- F.2.2.3. The sanding of the **mast** to reshape profiles or contours shall be prohibited.

F.2.3. Fittings.

- F.2.3.1. The following are permitted: mast head (crane) fitting, backstay batten, wind vane, sheaves and sheave boxes, tangs, spreaders, spreader attachments, gooseneck, boom vang fitting, compass and brackets, protective cloth sleeves, vinyl tapes for mast bands, manufacturer label, **certification mark**.
- F.2.3.2. Spreaders shall be supplied by the licensed manufacturer and shall be to the approved design.

F.2.4. Dimensions.

The **MHP** as used in the **ERS** is modified to be the top face of the mast foot casting, as per the drawing in these rules.

	Minimum.	Maximum.
Mast spar section above mast foot:		
Fore and aft:	115mm.	122mm.
Transverse:	74mm.	78mm.
Mast spar section at mast upper point:		
Fore and aft:	77mm.	88mm.
Transverse:	62mm.	70mm.
Start of taper above MHP:		
Constant section to this point	7950mm.	
Spar band widths:	15mm.	
Lower Mast Point.	710mm.	
Upper Mast Point.		9528mm.
Main Shroud height:	8270mm.	8290mm.

Lower Shroud height:	4160mm.	4180mm.	
Jib halyard height:	8210mm.	8230mm.	
Jib Halyard sheave Bearing Surface: diameter:		72mm.	80mm.
Spinnaker halyard height:	9455mm.	9475mm.	
Spinnaker Halyard sheave Bearing Surface: diameter:		30mm.	40mm.
Backstay crane: from aft face of mast:		320mm.	
Backstay crane:			
top aft corner vertically above Upper Mast Point:		235mm.	
Spreaders: number per side:		one.	
Spreaders:			
Length:	810mm.	830mm.	
Height:	4285mm.	4305mm.	
Angle:			
aft side of mast to taut line on aft side of shrouds:	230mm.	260mm.	

F.3. BOOM.

F.3.1. Manufacturer.

F.3.1.1. Manufacturers shall be approved by the Copyright Holder.

F.3.2. Materials.

F.3.2.1. The boom shall be made of aluminium and shall only be constructed from an ISAF approved section.

F.3.2.2. Coring, drilling out, rebuilding, replacement of material, grinding or relocating standard equipment that improve moments of inertia, or changes the standard shape shall be prohibited.

F.3.3. Fittings.

F.3.3.1. The following are permitted: Clew outhaul and fittings, sheaves and sheave boxes, blocks, cleats, hooks, spinnaker stowage fittings, reefing fittings, manufacturer label, **certification mark**.

F.3.4. Dimensions.

F.3.4.1. Tapered booms shall be prohibited.

F.3.4.2.		Minimum.	Maximum.
	Spar band width:	15mm.	
	Boom band distance:		3800mm.

F.4. BOW SPRIT.

F4.1. Manufacturer.

F4.1.1. Manufacturers shall be licensed by the Copyright Holder.

F4.1.2. The manufacturer shall, at his own expense, correct or replace any bowsprit that does not comply with the **class rules** as a result of an omission or error by the builder, if the bowsprit is submitted for **fundamental measurement** within twelve months of purchase.

F.4.1.3. Manufacturers shall only build bowsprits from moulds approved by the Copyright Holder and ISAF, or an organisation approved by the ISAF.

F.4.2. Materials

F.4.2.1. The **bow sprit** shall be constructed of carbon fibre reinforced materials specified within the manufacturers license.

F.4.2.2. Coring, drilling out, rebuilding, replacement of material, grinding or relocating standard equipment that improves moments of inertia, or changes the standard shapes shall be prohibited.

F.4.2.3. The sanding of the **bow sprit** to reshape profiles or contours shall be prohibited.

F.4.3. Fittings.

F.4.3.1. The following are permitted: Sheaves and sheave boxes, blocks, 'U' bolts, sheet catching batten, blanking off caps, manufacturer label, **certification mark**, tape or other materials for sealing against the rubber seal when pole is retracted. See **class rule C.6.3.1**.

F.5. STANDING RIGGING.

F.5.1. Manufacturer.

F.5.1.1. The manufacturer is optional.

F.5.2. Materials.

F.5.2.1. The standing rigging shall be of stainless steel cable only. Rod, diamond, Aramid (eg. Kevlar®) or similar shall be prohibited.

F.5.2.2. The backstay may be of any material, but if of other material than stainless steel cable in accordance with F.5.4, the backstay material shall have a nominal breaking strain of not less than 950kg.

F.5.3. Fittings.

F.5.3.1. The following are permitted: turnbuckles/bottlescrews, tangs, swages, swage eyes, shackles, shroud lock plates.

F.5.4. Dimensions.

	Minimum.	Maximum.
Main shroud diameter:	4.7mm.	5.1mm.
Lower shroud diameter:	4.7mm.	5.1mm.
Backstay diameter: stainless steel:	3.0mm.	

F.6. RUNNING RIGGING.

F.6.1. Manufacturer.

F.6.1.1. The manufacturer is optional.

F.6.2. Materials.

F.6.2.1 The jib halyard shall be stainless steel wire of 7 x 19 cable construction. It shall have a rope tail of optional size.

F.6.2.2 The main halyard and the spinnaker halyard may be from any material and may be tapered.

F.6.3. Dimensions.

	Minimum.	Maximum.
F.6.3.1. Main halyard:	4.7mm.	
Jib Halyard:	4.7mm.	5.1mm.
Spinnaker halyard:	4.7mm.	

F.7 ADDITIONAL RULES.

F.7.1. The main halyard shall be secured below deck only, using a sheet stopper and/or cleats mounted on the starboard side of the compression tube. It may be tensioned by a purchase of not more than 4:1 (including a cleat if required) and one hook or fastening. It shall not be lead to the deck nor be able to be operated from above deck.

F.7.2. The jib halyard shall be either secured to the tail of the high field lever system, or where a zip luff jib is used, the halyard may run internally in the zip luff and be secured by a locking system of optional design. In the latter system, the jib luff wire (G.4.2) shall be used as a forestay and secured in the normal way on the high field lever. A swivel may be inserted between the jib halyard and the jib luff wire.

F.7.3. The shrouds may be attached and adjusted by turnbuckles/bottlescrews of optional design except that only one thread is permitted per turnbuckle. Lock plates may be fitted to maintain the rig setting. They may be adjusted whilst racing, but at the chainplate only. Remote adjustment of any type is prohibited.

SECTION G - SAILS.

G.1. MEASUREMENT AND CERTIFICATION.

G.1.1. **Sails** shall conform with the **class rules** in force at the time of **fundamental measurement**.

G.1.2. Measurement shall be carried out in accordance with the **ERS**.

G.1.3. A MNA may appoint one or more persons at a sailmakers to measure and **certify sails** produced by that manufacturer. A special license shall be awarded for that purpose.

G.1.4. Sails shall carry the official certification mark near the tack point. The mark shall be signed and dated by the measurer. The certification mark shall be the individually numbered class stamp issued to each official measurer.

G.1.5. The weight in g/m² of the **body of the sail** shall be indelibly marked near the **head point** of the headsail and spinnaker by the sailmaker together with the date and his signature or stamp.

G.1.6. Substantially altered or repaired **sails** shall be re-measured and the measurer shall attach a new official **certification mark** showing the date of **fundamental measurement**.

G.1.7. Each **sail** constructed after 1st January 1997 shall have permanently fixed, (with stitching), near to its **tack point**, an official ICA label. No **sail** shall be accepted for its **fundamental measurement** without a sail label. The measurer shall sign across the label and sail to ensure that it cannot be transferred to another sail. Labels shall only be available from the ICA secretary (or treasurer) and the cost shall be fixed by the ICA in general meeting.

- G.1.8 The class insignia and the sail number and letters, as per rule B.3 shall be according to RRS 77 - Appendix H except where varied herein.
- G.1.9. Numbers and letters shall be of the following dimensions:
- | | | |
|---|----------|----------|
| | minimum. | maximum. |
| Height. | 300mm. | |
| Spacing between adjoining numbers or letters or edge of sail. | 60mm. | |
- G.1.10. The class insignia shall conform with the dimensions and requirements as detailed in the diagram contained in these rules. The word Melges shall be coloured mid to dark blue and the figures 24 shall be coloured teal green.
- G.1.11. The class insignia shall be positioned on both sides of the mainsail, between the top two battens, with the starboard side being higher.
- G.1.12. The national letters and sail numbers shall be positioned on both sides of the mainsail, between the second and third battens, with the starboard side being higher.
- G.1.13. In accordance with **RRS Appendix H5**, the national letters and sail numbers are optional on the spinnaker.

G.2. SAILMAKERS.

- G.2.1. The sailmaker is optional.

G.3. MAINSAIL.

G.3.1. Construction.

- G.3.1.1. The construction shall be: **Soft sail, single ply sail.**

- G.3.1.2. The **body of the sail** shall consist of **woven ply** and/or **laminated ply** made from one or more of the following materials: polyester, aramids, HMPE.
Sail reinforcement shall be made from one or more of the following materials: polyester, aramids, HMPE, glass fibre.
 N.b. Aramid is marketed under trade names such as Kevlar and Twaron and HMPE under trade names such as Spectra and Dyneema.

- G.3.1.3. The **sail** shall have 4 **batten pockets** in the **leech**. The upper two shall be full length and extend from **leech** to **luff**. The 4 **batten pockets** shall divide the leech into five equal parts, +/- 100mm.

- G.3.1.4. **Windows** are permitted below **half height**.

- G.3.1.5. One reef position may be fitted.

- G.3.1.6. The following are permitted: Stitching, glues, webbing, woven and PTFE tapes, bolt ropes, corner eyes, corner rings, Velcro or other fastening, Cunningham eye or block, reefing points, battens, batten pocket elastic, batten pockets, batten retaining devices, mast and boom slides, leech line with cleat, camber bands, ICA label, sailmakers labels as permitted by the ISAF, sail numbers, national letters and class insignia, tell tales, headboards and fixings, **certification mark**.

G.3.2. Dimensions.

	Minimum	Maximum
Leech length.		9590mm
Foot median.		9200mm

Three-quarter width.	1680mm
Half width.	2700mm
Top width.	175mm
Primary reinforcement.	unlimited
Secondary reinforcement:	
from corner measurement points.	unlimited
for flutter, chafing and batten pocket patches.	unlimited
for reefing points or eyes adjacent to the luff or leech.	unlimited
Tabling or seam width.	unlimited
Inside batten pocket length:	
Lower two pockets.	1780mm
Upper two pockets, (full length).	
Windows.	1.0m ²
Reef points above Tack and clew points.	1000mm

G.4. HEADSAIL

G.4.1. Construction.

G.4.1.1. The construction shall be: **Soft sail, single ply sail.**

G.4.1.2. The **body of the sail** shall consist of **woven ply** and/or **laminated ply** made from one or more of the following materials: polyester, aramids, HMPE.

Sail reinforcement shall be made from one or more of the following materials: polyester, aramids, HMPE, glass fibre.

N.b. Aramid is marketed under trade names such as Kevlar and Twaron and HMPE under trade names such as Spectra and Dyneema.

G.4.1.3. The shape of the **leech** shall not be convex.

G.4.1.4. The jib luff wire shall be 7x19 or 7x7 or 1x19 and may be coated or non-coated wire.

G.4.1.5. **Windows** are permitted below **half height.**

G.4.1.6. The following are permitted: Stitching, glues, webbing, woven tapes, luff wire, corner eyes, corner rings, Velcro or press studs, Cunningham eye with cleat, leech line with cleat, foot line with cleat, camber bands, ICA label, sailmakers labels as permitted by the ISAF, tell tales, two blocks for sheets, zip for luff sleeve, **certification mark.**

G.4.1.7. For headsails manufactured after the 1st July 1997, the weight of the cloth in the **body of the sail** shall comply with the minimum listed in **class rule** G.4.2. and shall be subject to **class rule** G.1.5.

G.4.1.8. The headsail may be fitted with a maximum of three battens. The battens shall have one end placed on the leech. The battens may be permanently attached to the sail or removable. They shall not be removed for measurement. The batten material is unrestricted. The battens shall not prevent the headsail from completely furling.

	Minimum	Maximum
Batten length		1500mm
Batten width	10mm	35mm
Batten pocket position on leech from clew	750mm	6000mm
Foreward most point of batten from leech		800mm

G.4.2. Dimensions (to be measured as a headsail)

	Minimum	Maximum
Luff length.	8460mm	8560mm
Leech length.	7775mm	7903mm

Foot length.	2926mm	3026mm
Top width.		50mm.
Primary reinforcement.		unlimited
Secondary reinforcement.		
from corner measurement points.		unlimited
for flutter and chafing patches.		unlimited
Tabling and seam width.		unlimited
Windows.		0.75m ²
Cloth Weight.	200g/m ²	
Luff wire. Diameter.	4.7mm	5.1mm
Luff wire length between bearing surfaces.	8520mm	8700mm

G.5. SPINNAKER.

G.5.1. Construction.

G.5.1.1. The construction shall be: **Soft sail, single ply sail.**

G.5.1.2. The **body of the sail** shall consist only of **woven ply**. All **ply** fibres shall be of non polyester material. Primary reinforcement may include other materials.

G.5.1.3. **Windows** are permitted below **half height**.

G.5.1.4. The following are permitted: Stitching, glues, webbing, woven tapes, corner eyes, corner rings, camber bands, sailmakers labels as permitted by the ISAF, sail numbers and national letters, ICA labels, tell tales, leech lines, luff lines, foot lines, **certification mark**.

G.5.2. Dimensions (to be measured as a spinnaker)

	Minimum	Maximum
Luff length.	11285mm	11585mm
Leech length.	10000mm	11078mm
Foot length.	6000mm	6300mm
Foot median.		12000mm
Three-quarter width.		3700mm
Half width.		5860mm
Primary reinforcement.		unlimited
Secondary reinforcement.		
From corner measurement points.		unlimited
Tabling and seam width.		unlimited
Windows.		0.75m ²
Cloth weight.	40gms/m ²	

G.6. ADDITIONAL RULES.

G.6.1. The **headsail** shall be capable of being fully furled around the forestay, from the cockpit, using the furling system supplied with the boat.

G.6.2. The mainsail shall be set so that: the **head point** is not above the lower edge of the **upper mast band**, the **tack point** is not below the upper edge of the **lower mast** and the **clew point** is forward of the inner edge of the **boom band**.

G.6.3. Double luff sails are prohibited.

G.6.4. The mainsail shall be attached to the boom only at the clew.

- G.6.5. Sails made of laminated materials shall have a woven material patch fixed at the tack on which the sail can be endorsed by the measurer.
- G.6.6. The jib wire shall be enclosed in a pocket. A zip luff may be fitted, it shall not be used to alter the shape of the sail in anyway.
- G.6.7. Mainsail leech hollows shall be measured in accordance with the **ERS**.

© ISAF 2002

APPENDIX – MEASUREMENT DIAGRAMS

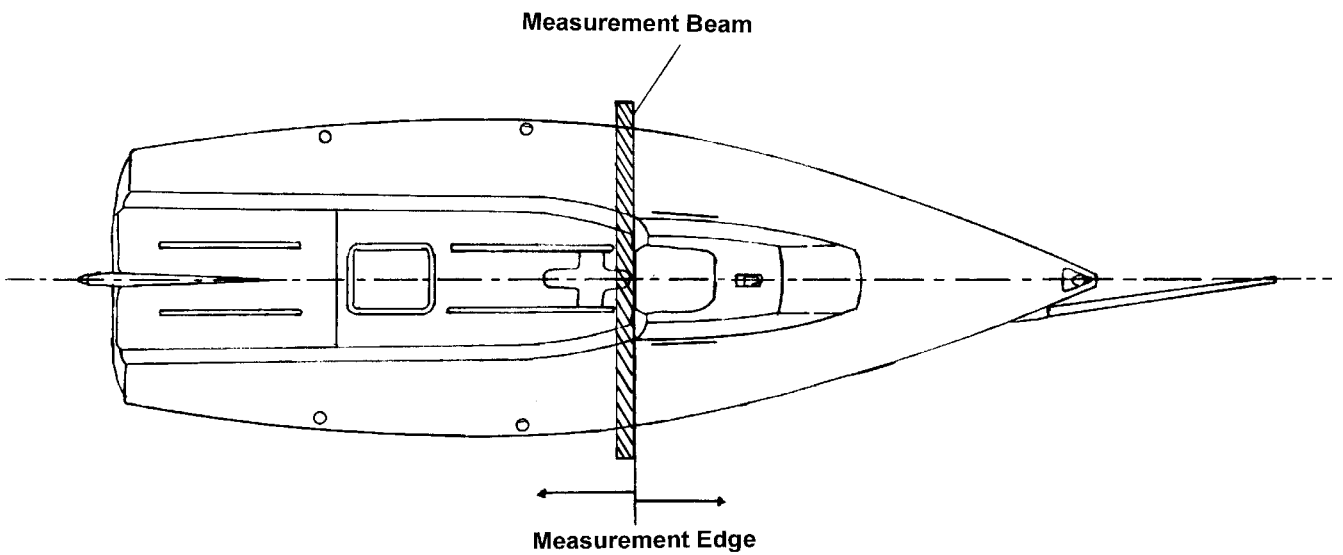
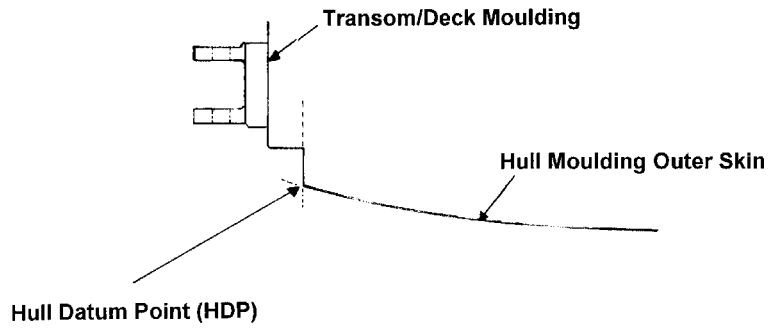
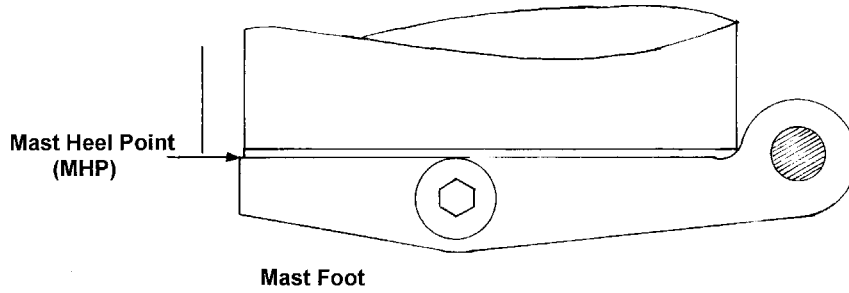

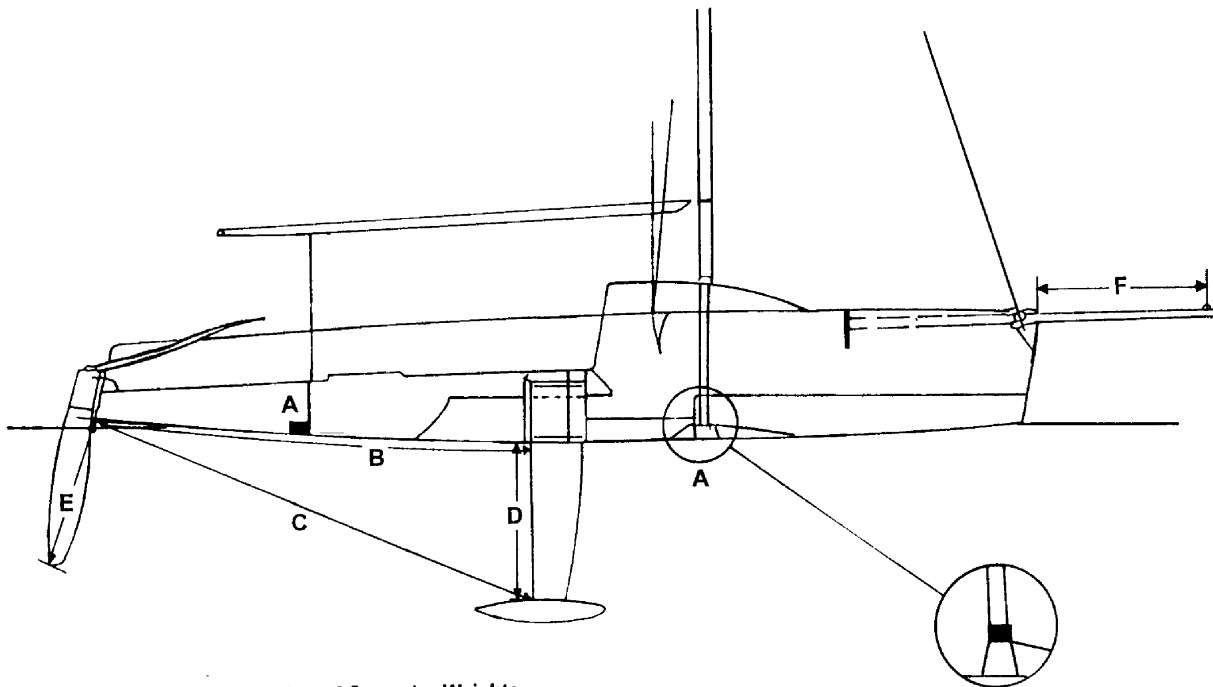

- Key:
- A = Position of Corrector Weights
 - B = 3482 → 3494mm (Class Rule E 3.3.1)
 - C = 3784 → 3823mm (Class Rule E 3.3.2)
 - D = 1195 → 1215mm (Class Rule E 3.3.3)
 - E = 1220mm max. (Class Rule E 4.3.2)
 - F = 1400mm max. (Class Rule C 6.3.2)

Equal weights secured on either side of mast compression post

Illustration regarding dimension C corrected 5th February 1998

Note: On all measurements (excluding angles) relating to the class insignia there is a tolerance of +/- 5mm.

